

D12D-B MH, D12D-C MH, D12D-A MP, D12D-C MP

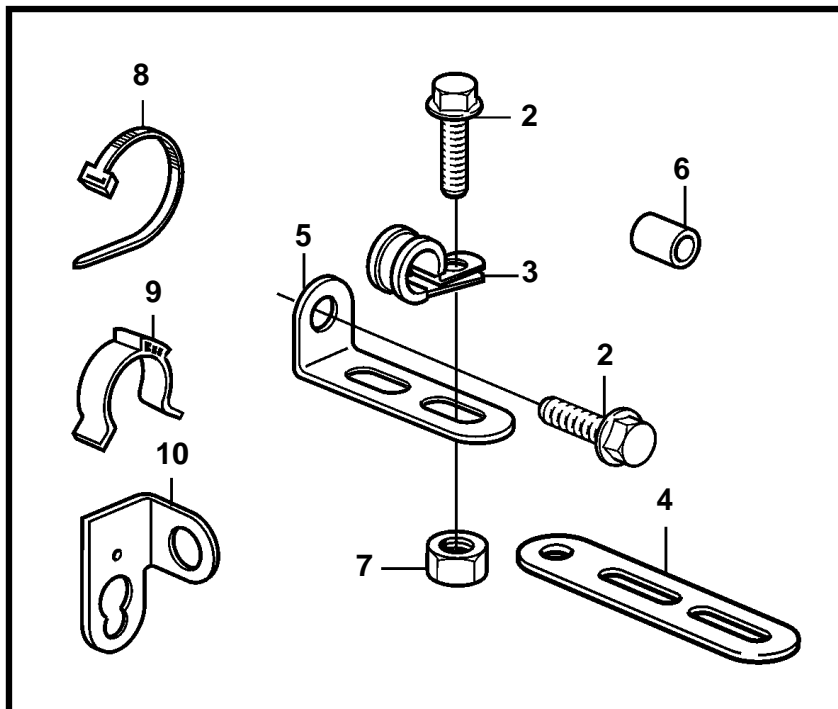
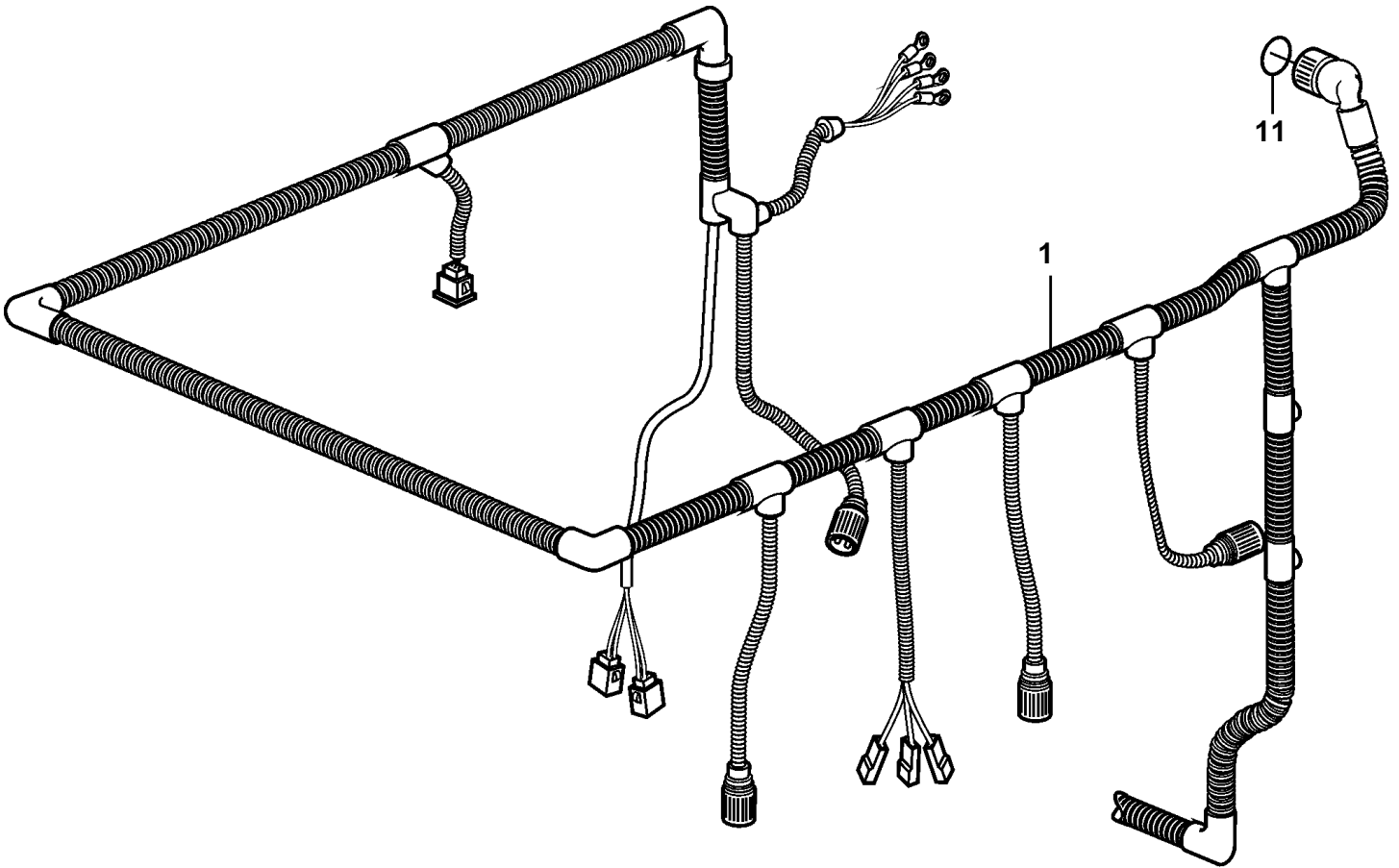

19958

D12D-B MH, D12D-C MH, D12D-A MP, D12D-C MP

REF	PART NO.	QTY	DESCRIPTION	NOTES
1	3807040	1	Wiring harness	
2	946440	X	Flange screw	M8x16mm
	946441	1	Flange screw	M10x20mm
3	949746	3	Clamp	I.D.=12,7mm
	949747	1	Clamp	I.D.=15.7mm
	947827	9	Clamp	I.D.=25,4mm
4	965543	1	Bracket	
5	965559	7	Bracket	L=80mm
	965562	2	Bracket	L=110mm
6	821540	1	Spacer sleeve	L=22mm
7	945408	X	Flange nut	
8	983472	X	Cable tie	L=148mm
	948211	X	Cable tie	
9	28429850	5	Retainer	
10	3988328	1	Bracket	
11	949721	1	O-ring	